

ASSEMBLY NOTES:

1. REFER TO SCALE MANUAL FOR FULL INSTALLATION AND OPERATION INSTRUCTIONS.
2. KEEP ALL SHIP BOLTS AND CHECK BOLTS SECURED UNTIL ALL INSTALLATION AND APPROACH RAMP WORK IS COMPLETE.
3. PLACE CENTER-BASE MODULE FIRST, FOLLOWED BY END MODULES. PLACE MODULES WITH JBOX MOUNTS ALL ON ONE SIDE AS SHOWN.
4. BOLT END PANELS TO CENTER-BASE PANEL & SET ANCHORS IN SECTION STANDS.
5. IF UNABLE TO ANCHOR STANDS, INSTALL BRACES BETWEEN BULKHEADS AND SECTION STANDS.
6. AFTER ALL APPROACH WORK IS COMPLETED, REMOVE SHIPPING BOLTS AND SET PROPER GAPS OF BUMPER (CHECK SYSTEM) BOLTS.
7. KEEP SHIPPING HARDWARE FOR LATER USE.

NOTES:

1. FOUNDATION SHOWN IS DESIGNED FOR SOILS WITH A MINIMUM BEARING CAPACITY OF 3000 PSF AND ADEQUATE DRAINAGE. IF SOIL CONDITIONS DO NOT MEET THESE REQUIREMENTS, ADJUST FOUNDATION OR SOIL CONDITIONS AS REQUIRED.
2. IN AREAS OF THE COUNTRY WHERE THERE IS SEVERE FREEZING, INCREASE THE DEPTH OF THE FOUNDATION SO THAT THE BOTTOM EXTENDS BELOW THE FROST LINE, OR PROVIDE A MINIMUM OF 12\"/>

FOUNDATION CONCRETE REQUIREMENTS	
4000 P.S.I.	
AREA	QUANTITIES
PIERS AS SHOWN	10 CU. YD.
FLOOR AT 2\"/>	

FOUNDATION REINFORCING BAR SCHEDULE				
ASTM A615 GRADE 60				
MARK NO.	REQ'D.	SIZE	LENGTH	WT.
HR1	85	#4	9'-6\"/>	

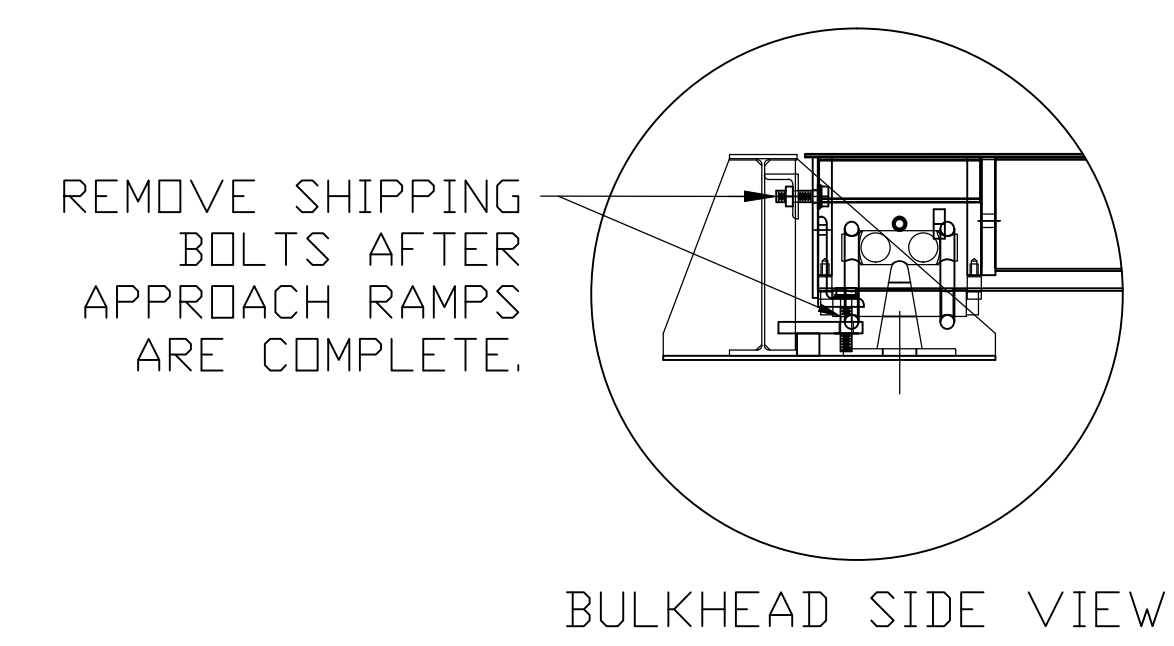
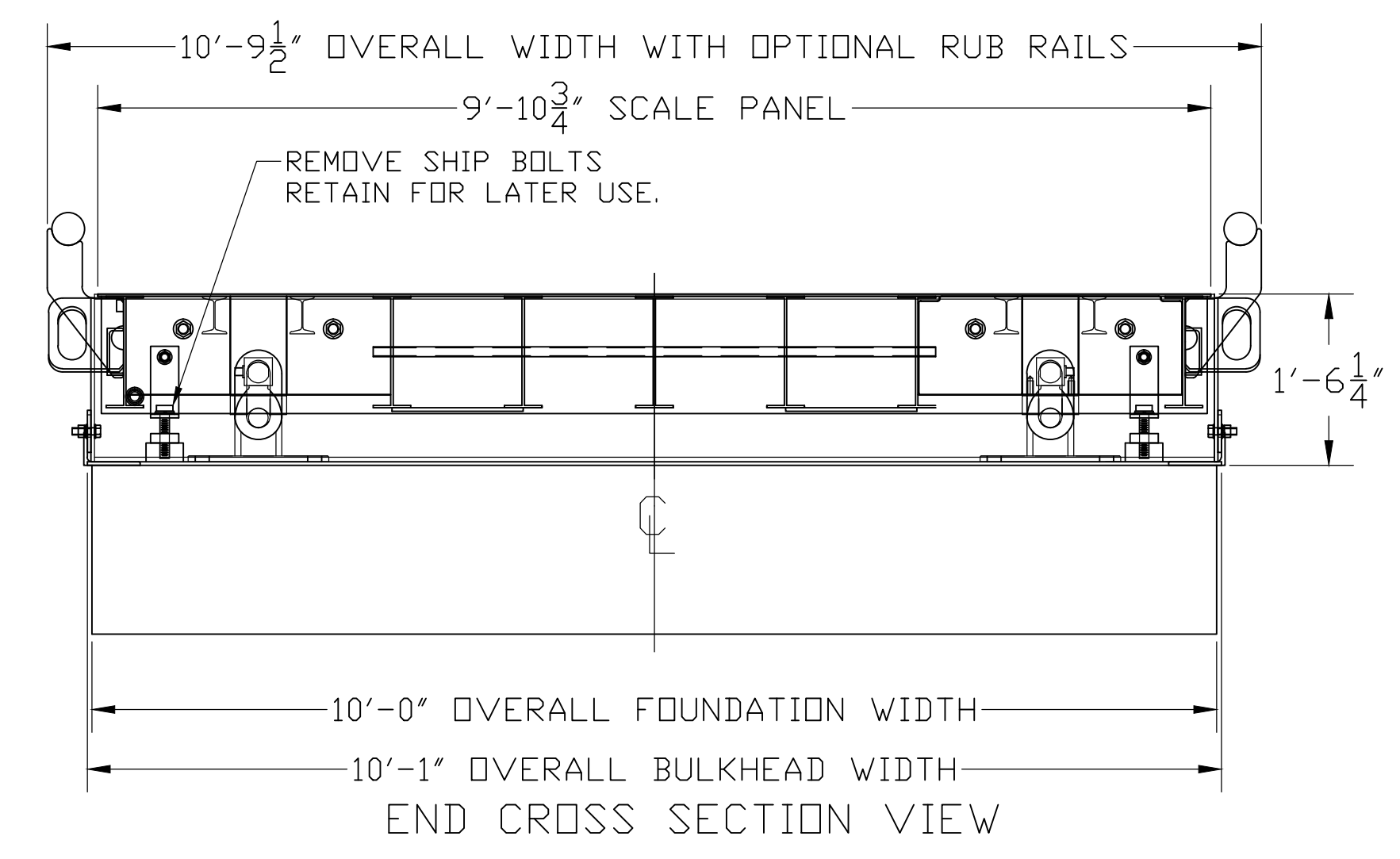

THIS DRAWING IS SUPPLIED AS CHECKED BELOW:
 REFERENCE (ESTIMATES ONLY, NOT FOR CONSTRUCTION)
 CERTIFIED FOR CONSTRUCTION, THURMAN #
 CUSTOMER: _____ DATE: _____
 CUSTOMER APPROVAL, RETURN ONE COPY.
 (ORDER ON HOLD UNTIL SIGNED COPY IS RETURNED)
 APPROVED AS DRAWN, APPROVED BY: _____ DATE: _____
 APPROVED AS NOTED, APPROVED BY: _____ DATE: _____

LET	BY	DATE	REVISION
1	JCR	2/1/12	REVISED APPROACH NOTE, ADDED BRACES

THURMAN SCALE
COLUMBUS, OH
8560 DIAMONDBACK 80' X 10' PV
FOUNDATION (90K CLC, 5 SECT. DB)

DATE: 5/19/08
SCALE: N/A
SHEET 1 OF 1
DRAWN BY: NDC
CHECKED BY: _____
APPROVED BY: _____

DRAWING NUMBER: 92391-PV
REVISION: 1

THE MATERIAL AND INFORMATION CONTAINED HEREIN IS CONFIDENTIAL AND IS THE PROPERTY OF THURMAN SCALE COMPANY AND IS NOT TO BE USED, DISCLOSED, COPIED, TRANSMITTED, OR REPRODUCED WITHOUT THE PRIOR WRITTEN PERMISSION OF THURMAN SCALE COMPANY.

UNLESS OTHERWISE SPECIFIED: DIMENSIONS ARE IN INCHES TOLERANCES: FRACTIONS 1/8\"/>